

1 2 3 4 5 6

A

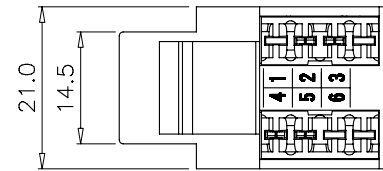
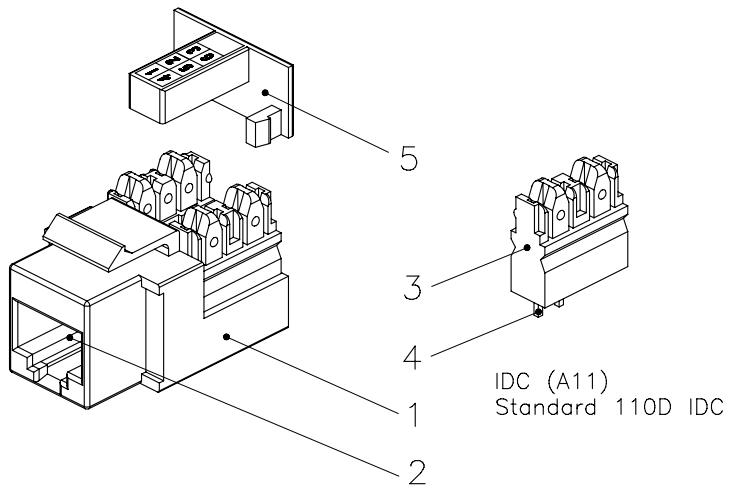

B

SCALE 1/1

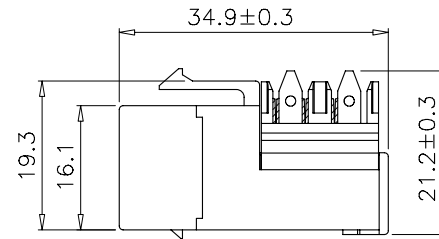
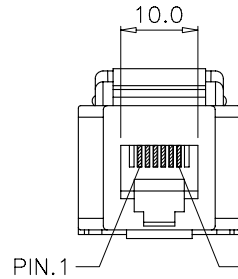

B

Specification :

Material :

1. Plastic Housing : ABS, UL 94V-0.
2. RJ45 Contact material & finished :
 - 2-1. Phosphor Bronze with 30-40 micro-inch Nickel plated.
 - 2-2. Contact area : Min. 3 mm 50 micro-inch Gold plated.
3. IDC Housing : Polycarbonate, UL 94V-2.
4. IDC Terminal material & finished :
 - 4-1. Phosphor Bronze with 50 micro-inch Tin plated.
 - 4-2. 110 tool only.
 - 4-3. Use for 22-26 AWG stranded & solid wire.
5. IDC Bracket : ABS, UL 94V-0.

Performance :

- a. Insertion Force : 900 gms for 8 contacts.
- b. Retention Strength : 7.7 kgs between Jack and Plug.
- c. Operation Temperature : -40°C to 80°C.
- d. Durability :
 - d-1. Jack : 750 cycles Plug-Jack mating and unmating test, insertion cycles at 20 cycles/minute max. Contact resistance test per 100 cycles.
 - d-2. IDC : Max. 200 punching times.

D

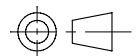
GENERAL TOLERANCE OF DIMENSIONS X.XXX ±0.005 X.XX ±0.05 X.X ±0.1	DRAWING	06.JUN.2006	WB	 COMMODITY CABLES, INC. www.commoditycables.com
	CHECK	06.JUN.2006	VICKY	
	APPROVAL	06.JUN.2006	JAIMY	
	DATE			
	SCALE	1/1 (A4)	UNIT	
 DRAWING NO.		DRAWING CLASSIFICATION		1 OF 1

1 2 0 3 4 10cm 5

A1